

# Tripod Turnstiles

## **DURAPOD** DT 400

Robust turnstiles for heavy traffic use with stainless steel arms. Bi-directional, logic controlled, LED indicators included on both entrance and exit sides. Hand operated; hand operated with drop arm; motor driven with drop arm options available.

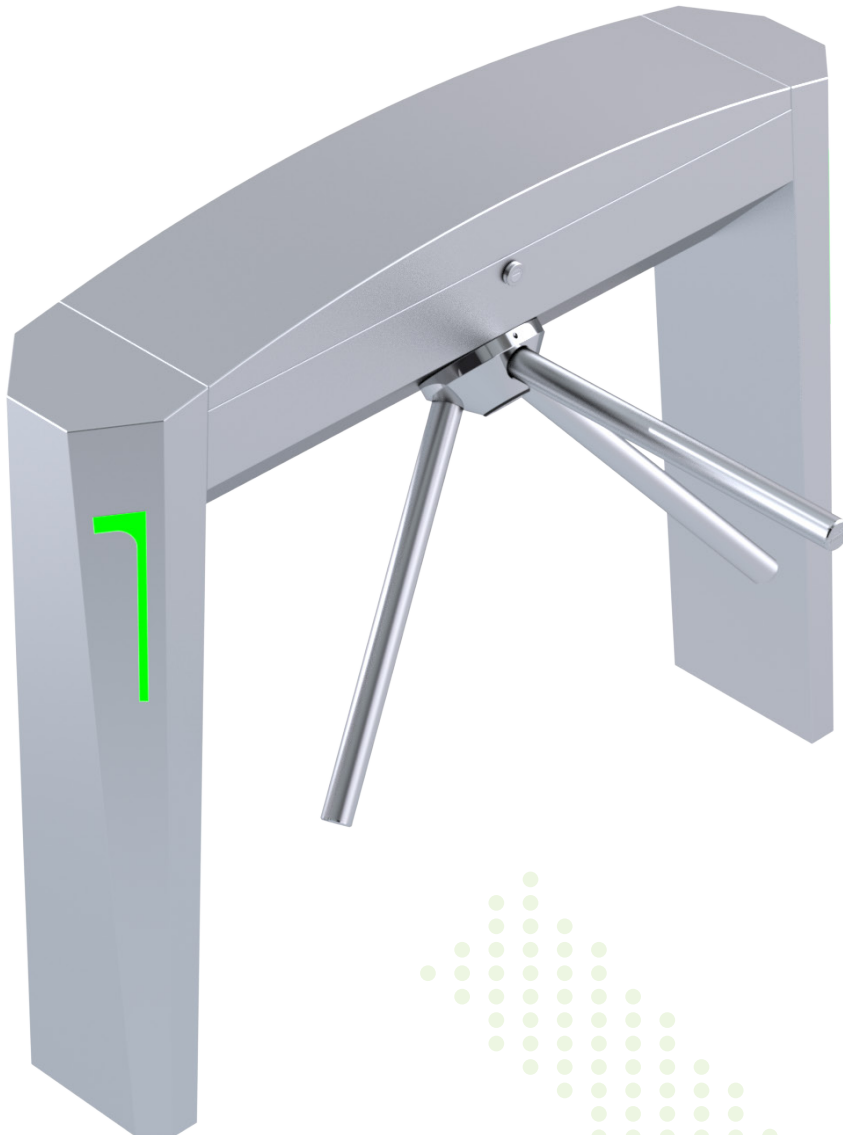

# Tripod Turnstiles

## DURAPOD DT 400

### MATERIALS

2,0 mm AISI 304 stainless steel housing. Stainless steel lid and arms.  
Cast & machined aluminium tripod hub.

### DRIVE MECHANISM OPTIONS

- Electromechanical, hand operated.
- Electromechanical, hand operated with drop arm.
- BLDC Motor driven with drop arm.
- A self centring mechanism to ensure complete rotation of the mechanism to the home position.
- A hydraulic damper to ensure smooth operation
- Anti backup device to prevent reverse rotation once the mechanism has moved 30 degrees from the home position
- Fail-safe operation as standard. (Optional fail-locked)

### FUNCTIONS & INTERFACE

- Logic controlled interface, bi-directional operation
- Entrance and exit directions can be individually set as controlled, locked or free before or after the installation.
- In controlled access mode, after release confirmation which was sent by access control system, the turnstile unlocks the released direction and enables one person access in the direction of travel. After each person, the turnstile arm blocks passage again and does not permit access from both entrance and exit directions until receiving a new release signal from the access control system.
- After the release, the turnstile blocks itself after an adjusted time if no transition or passage occurs.
- If people from both directions would like to pass through simultaneously, the first person who activates the turnstile takes precedence.
- An additional person is able to release the next passage cycle during an ongoing passage cycle in both directions. The turnstile controller stores up to 255 releases and lets corresponding number of individuals pass through.
- Relay outputs for counting passage in either direction
- RS 232 serial port

### EMERGENCY & POWER CUT

In the event of emergency or power-cut the mechanism unlocks the arms and the arms rotate freely in both directions. The turnstile reset itself automatically when the emergency alarm stops or the power is switched back on.

### LED INDICATORS

LED lights indicates the operating status of the turnstile in both directions.

	Option-1	Option-2
Green	Standby or locked	Released or free passage
Red	Released or free passage	Standby or locked

### SETTINGS

Operation mode for each directions	: Controlled / Free / Locked
Acoustic Notifications	: On/Off
Release time out	: 5-10-15-20 secs
Consecutive passage	: On/Off
Emergency connection	: On/Off
LED Indicator options	: Option-1 / Option-2

### SPECIFICATIONS:

**Construction:** Steel  
**Passage width:** 560 mm  
**Arm length:** 510 mm  
**Cabinet size (W x L x h):** 250 x 1200 x 1044 mm  
**Weight:** 49 Kg  
**Power Supply:** 100 - 240 VAC, 50/60 Hz  
**Logic Voltage:** 24V DC  
**Standby power consumption:** 3.8 W  
**Operation Temperature:** -10 ° / +70 °  
**IP Protection:** Cabinet IP54 / Logic Controller IP65

### HOUSING MATERIAL OPTIONS

- AISI 304 Stainless steel (Standard)
- AISI 316 Stainless steel
- Powder coated steel in RAL colours

### ACCESSORIES:

- Stainless steel apron infill
  - Tempered glass infill
  - Mounting plate for raised/suspended floor
  - Ramp plate
  - Heating kit for -40 degrees
  - Jump over & crawl under sensor kit integration
  - Additional LED indicator pictogram on the lid or on the leg
  - Back-up battery 7A
  - Access controller integration options
- (Please contact with sales representative for full list of options and accessories)

